

steam turbine

Pioneering work in repair and maintenance of steam turbines.
Unique facility in the production and repair of turbine components.

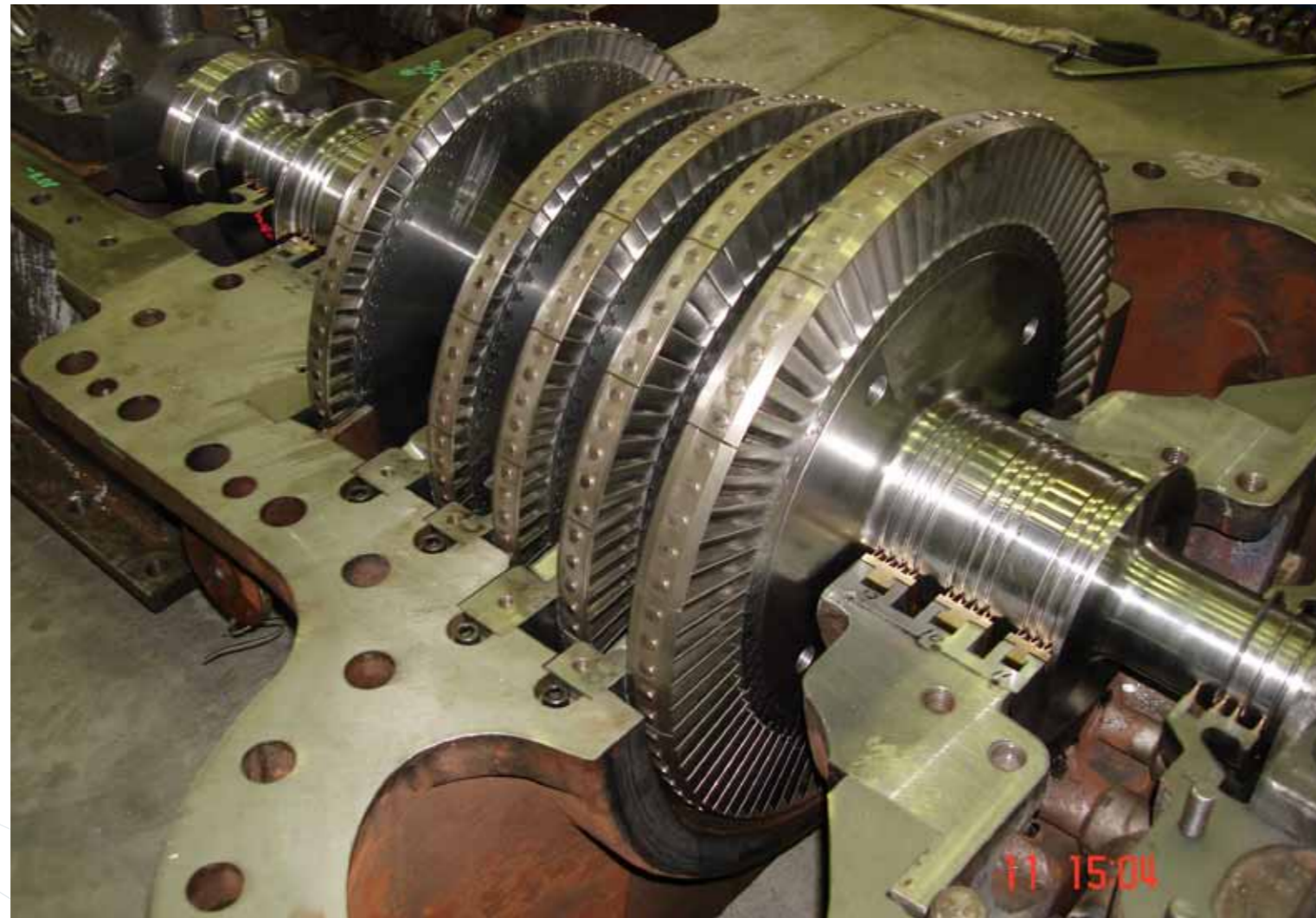

Steam Turbine Department

KIMI SA specializes in the manufacture and repair of steam turbine parts that are made based on samples or our customer's documentation and drawing, using the reverse engineering method and utilizing the most reliable and effective procedures.

Products & Services

Experienced and specialized personnel using the latest state of the art engineering equipment provide the ability to respond even to the most complex requirements of production and repair. For more than 20 years, KIMI SA offers manufacture or repair of the following:

- Steam turbine blades (rotating and stationary)
- Rotor shafts
- Nozzles
- Diaphragms
- Bearings
- Labyrinths
- Casing
- Valve Box and Pilot Valves
- Dynamic Balancing



Steamturbines

Quality Control of Raw Materials and Final Products

Raw materials are accompanied by required certification and undergo exhaustive examination by the company's certified Quality Control Department.



All manufactured or repaired steam turbine parts are subject to a series of checks and non-destructive tests in order to ensure that they satisfy technical specifications.

Steam turbines

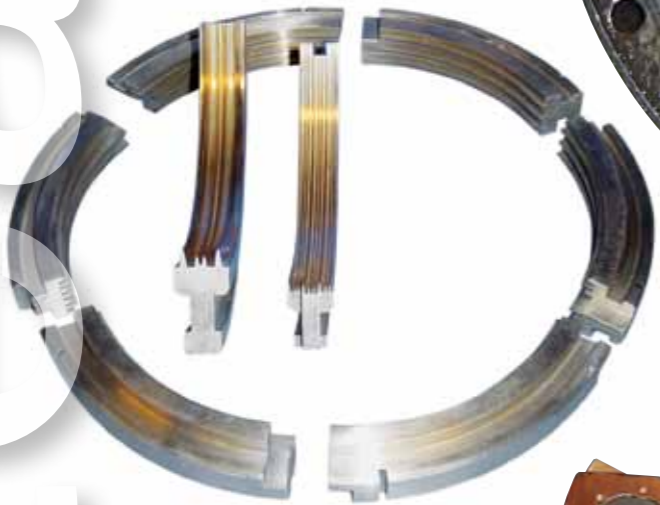

Quality Assurance

The system of quality control management applied by the company covers each step of the production, ranging from the arrival and testing of raw materials to the delivery of final products to the customer. The quality of our products is assured by the quality management system approved by the certificate ISO 9001:2000.

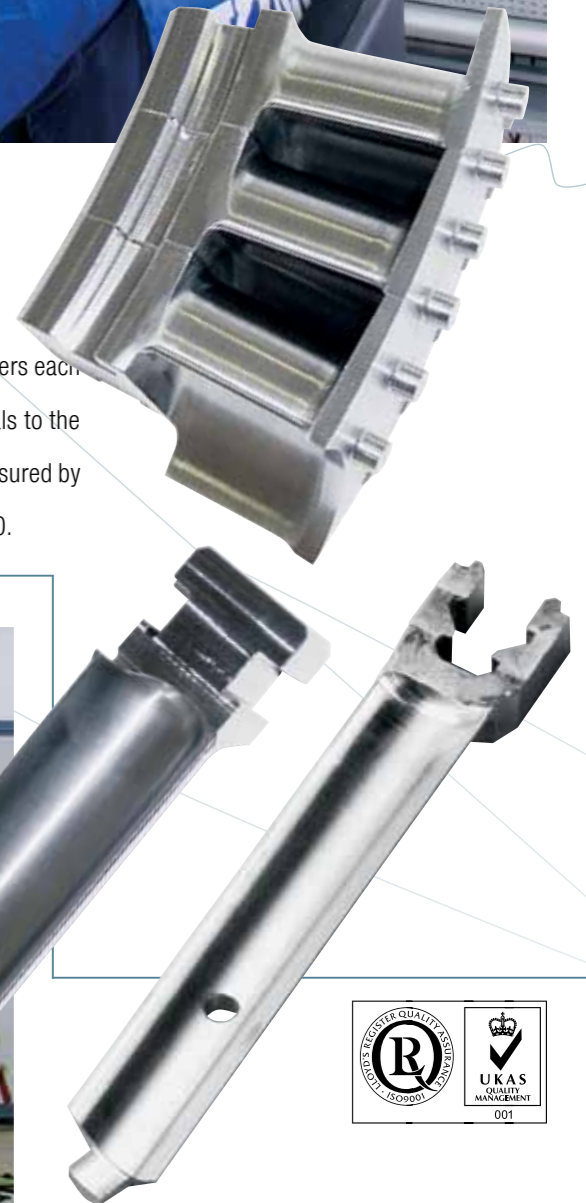



Industrial Park of SHISTO
2nd Block, 2nd Street
Perama 188 63, Greece
Tel: +30(210) 4004757
Fax: +30(210) 4326399
Web: www.kimi-sa.com
E-mail: info@kimi-sa.com